

- 1 cylinder
- 441 cm³
- 8,0 kW/10,9 HP
- 3600 rpm
- Nm 24,5@2200

Available homologation

- EPA TIER II ●
- ECE R 24 ▲

Construction

- 4 -stroke air cooled diesel engine.
- Conical power take-off on crankshaft.
- Anticlockwise rotation.
- Direct injection.
- Forced lubrication with oil pump.
- Centrifugal mass governor.
- Built-in full flow oil filter.
- Oil breathing blow-by with safety device.
- Automatic extra fuel starting device.
- Self bleeding fuel system.
- Torque regulator.
- Automatic compression release.
- Die-cast aluminium crankcase with integral cast iron cylinder liner.
- Aluminium alloy cylinder head.
- Built-in rigid feet.
- Hydraulic tappets.



Applications

- Two-wheel tractor
- Agricultural mower
- Agricultural pump
- High pressure cleaner
- Generating set
- Vibrating plate

Specifications

Cylinders	N.	1
Displacement	cm ³	441
Bore	mm	86
Stroke	mm	76
Compression ratio		20,3:1
Rating kW/HP	N (80/1269/CEE) ISO 1585	8,0/10,9
	NB ISO 3046 IFN	7,4/10,1
	NA ISO 3046 ICXN	6,7/9,1
Max. torque	Nm	24,5@2200
Min. idling speed		1050÷1150
Fuel tank capacity	l	5
Oil consumption	kg/h.	0,0048
Oil sump capacity	l	1,5
Min. allowable oil pressure	bar	1÷1,5
Max. allowable inclination for:		
- short periods of operation (max. time 30 minutes)		25°
- peak values (max. time 1 minute)		35°
Cap. of air required for correct combustion @ 3600 r.p.m.	l/min.	640
Cap. of air required for correct cooling @ 3600 r.p.m.	l/min.	5500
Dry weight	kg	45
Recommended battery	V/Ah	12/44
Minimum pulley diameters for belt drive		

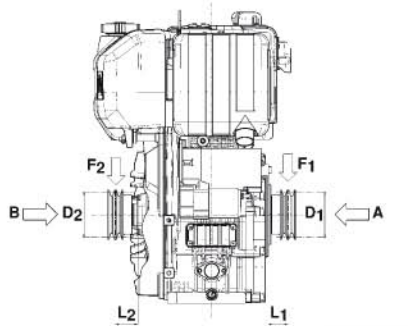
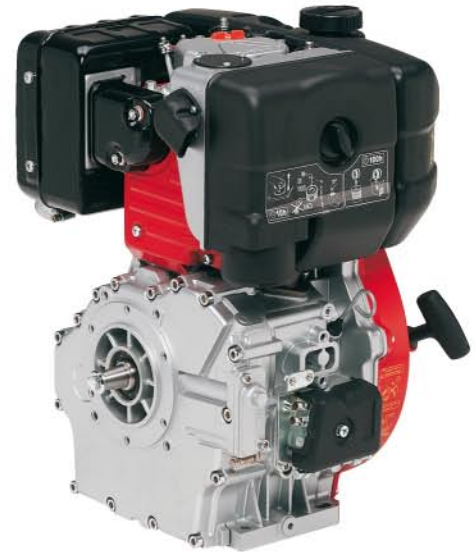

$$D_2 \text{ (mm)} \geq 620 [66 + L_2 \text{ (mm)}] \frac{N \text{ (kW)}}{n \text{ (RPM)}}$$

$$D_1 \text{ (mm)} \geq 650 [53 + L_1 \text{ (mm)}] \frac{N \text{ (kW)}}{n \text{ (RPM)}}$$

Max. intermittent axial load in both directions A-B = 200 kg

$$F_2 \text{ (N)} \leq \frac{92000}{66 + L_2 \text{ (mm)}}$$

$$F_1 \text{ (N)} \leq \frac{89000}{53 + L_1 \text{ (mm)}}$$

Maximum radial force on pulley for belt drive

Sound pressure level dB (A)

Sound level polar diagram open field - 7 meters microphone - no load running engine.

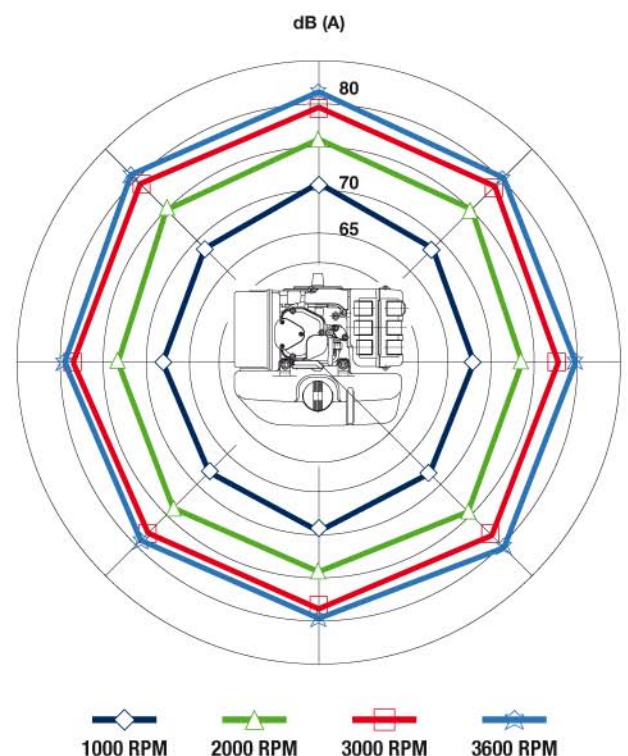

SERIE 15LD

Curves 15LD 440 ▲

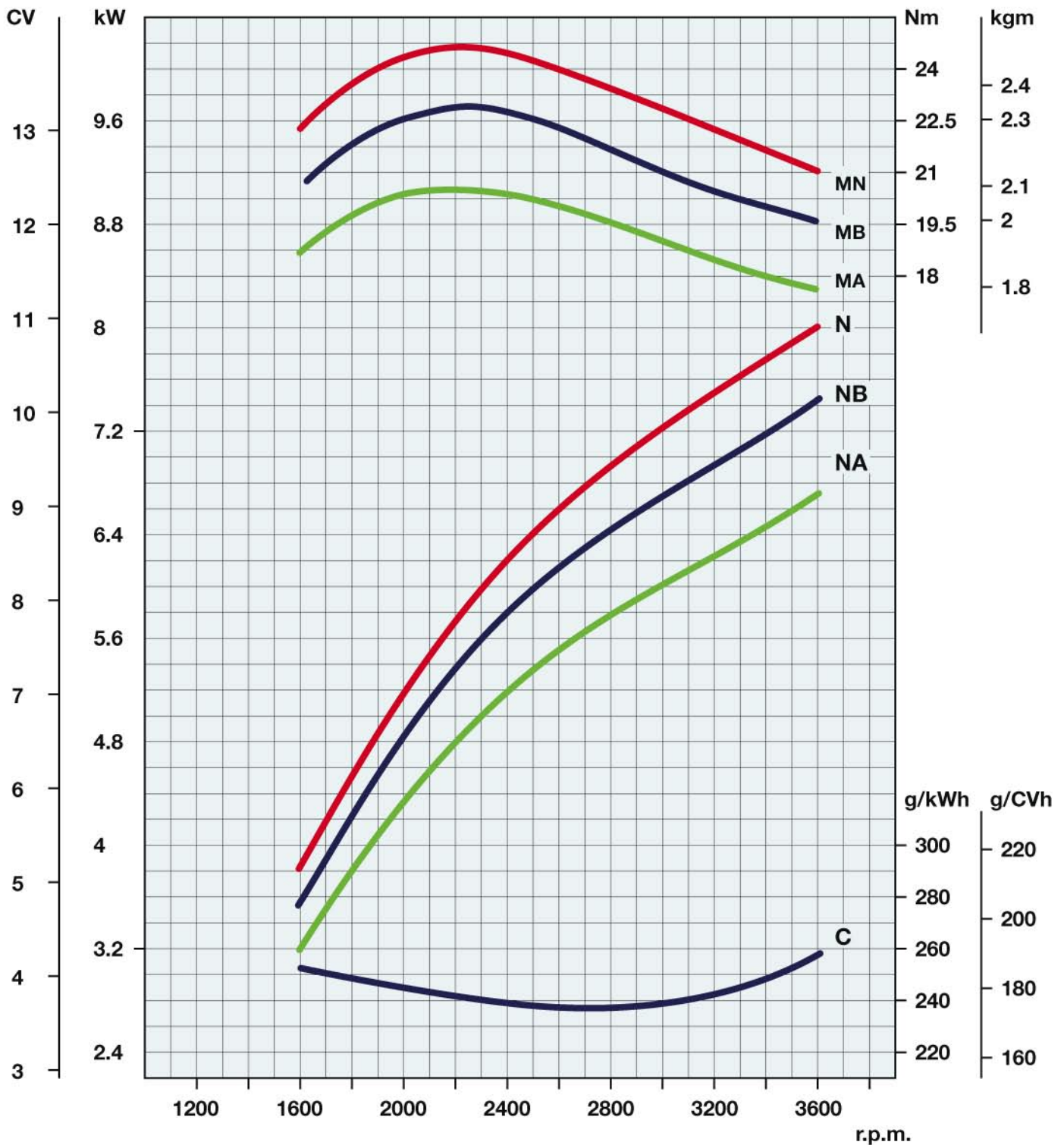

N Power curve - 80/1269/CEE - ISO 1585 -

NB Power curve - ISO 3046 - IFN -

NA Power curve - ISO 3046 - ICXN -

MN Torque curve - (N curve)

MB (NB curve) - **MA** (NA curve)

C Specific fuel consumption - (NB curve)

Power ratings refer to engines equipped with air filter, standard muffler, after being run in and in ambient conditions of 20°C and 1 bar. Power levels drop by 1% every 100m altitude and by 2% every 5°C above 20°C.

Technical drawings *

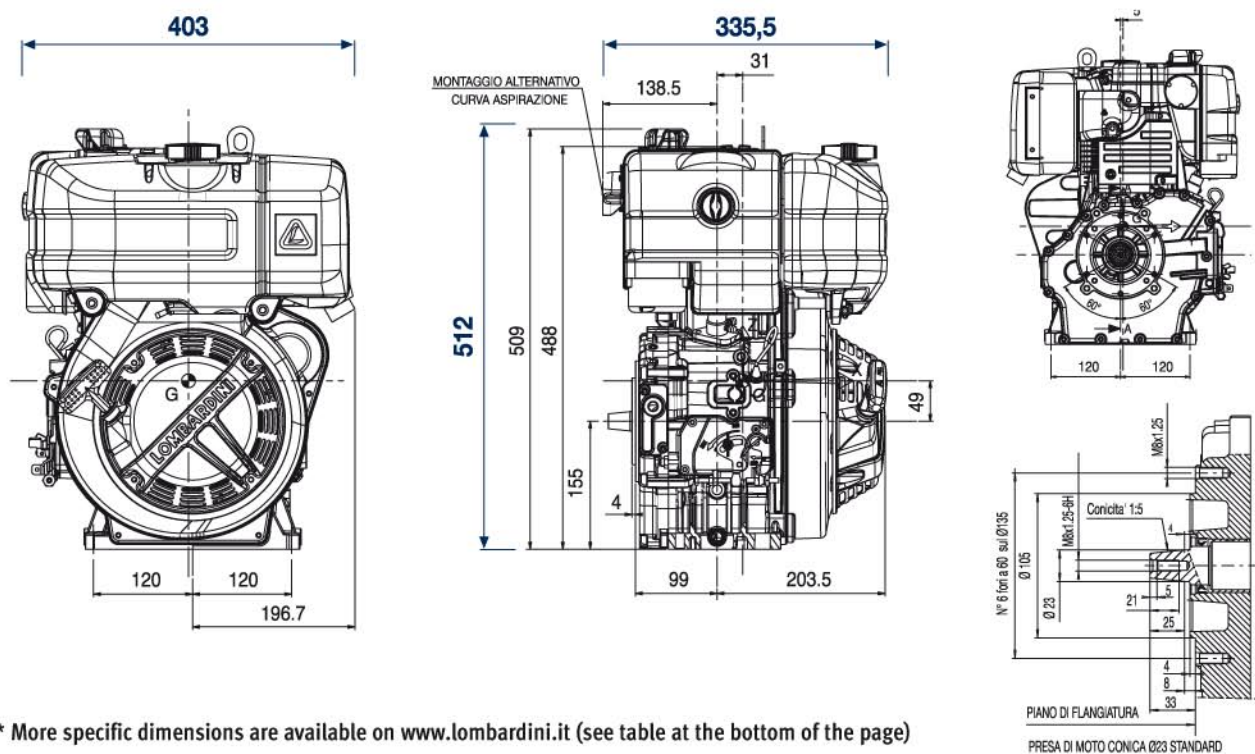

* More specific dimensions are available on www.lombardini.it (see table at the bottom of the page)

Standard equipment

- Recoil starting and automatic compression release
- Fuel tank
- Fuel filter
- Dry-air cleaner
- Muffler with guard
- Accelerator and stop manual control
- User maintenance-spare parts booklet

Accessories

- Power take-off flywheel side (engines with electrical starting)
- Power take-offs with flanging and special shaft
- Parallel crankshaft
- Internal dynamic balancer
- Oil-bath air-cleaner
- Electric start 12 V / 24 V
- Keyswitch panel
- Emergency stop through electrovalve
- Accelerator and stop remote control
- Key start panel with shutdown device
- Fuel lift pump
- Oil dipstick on cylinder head
- Oil pressure switch
- Oil temperature switch
- Glow plug on intake manifold
- Recoil with denoising cover
- Grass protection for engine cooling



ISO 9001 Cert. n. 0446 - 1405
QS. 9000 Cert. n. 2231/0

LOMBARDINI
A KOHLER COMPANY

Via Cav. del Lavoro Adelmo Lombardini, 2
42100 Reggio Emilia Italia
Tel. ++39 0522.3891 Fax ++39 0522.389503
www.lombardini.it

Files for this product available on www.lombardini.it

Data sheet	15LD440DS.PDF
Owner manual	15LD440OM.PDF
Service manual	15LD440SM.PDF
Technical drawing	15LD440TD.DWG
Power curve	15LD440PC.PDF

LOMBARDINI RESERVES THE RIGHT TO MAKE MODIFICATIONS WITHOUT PRIOR NOTICE

cod. 3558091 - 07-2008